



PureCharge
3-Stage Automatic Intelligent
Battery Charger



Contents

1. Important Safety Instructions.....	1
1-1 General Safety Precautions.....	1
1-2 Precautions When Working With Batteries.....	2
2. Features.....	3
2-1 Battery Charging Curve.....	3
2-2 Electrical Characteristic.....	4
2-3 Mechanical Drawings.....	5
3. Introduction.....	6
3-1 Front Panel Operations.....	6
3-2 Rear Panel Operations.....	7
3-3 Troubleshooting.....	8
3-4 Selection Of Battery Type.....	8

1. Important Safety Instructions



WARNING!

Before you install and use your PC Battery Charger, be sure to read and save these safety instructions.

1-1. General Safety Precautions

- 1-1-1. Do not expose the PureCharge Battery Charger to rain, snow, spray, bilge or dust. To reduce risk of fire hazard, do not cover or obstruct the ventilation.
Do not install the PureCharge Battery Charger in a zero-clearance compartment, overheating may be result.
- 1-1-2. To avoid risk of fire and electronic shock, make sure that existing wiring is in a good electrical condition; and that wire size is not undersized. Do not operate the PureCharge Battery Charger with damaged or substandard wiring.
- 1-1-3. Do not charge non-rechargeable batteries.
- 1-1-4. During charging, the battery must be placed in a well-ventilated area.
- 1-1-5. The battery charger must only be plugged in to an earthed AC outlet.
- 1-1-6. If the power supply cord is damaged, it must be replaced by the manufacturer or its service agent or a similar qualified person in order to avoid a hazard.



1-2. Precautions When Working With Batteries

- 1-2-1. If battery acid contacts skin or clothing, wash immediately with soap and water. If acid enters eye, immediately flood eye with running cold water for at least 20 minutes and seek immediate medical care.
- 1-2-2. Never smoke, allow a spark, or flame in the vicinity of battery or engine.
- 1-2-3. Do not drop a metal tool on the battery. The resulting spark or short-circuit on the battery or other electrical part may cause an explosion.
- 1-2-4. Remove personal metal items such as rings, bracelets, necklaces, and watches when working with a lead-acid battery. A lead-acid battery produces a short-circuit current high enough to weld a ring or the like to metal, causing a severe burn.

2. Features

- High-performance 3-stage charging effect
- 0.98 typical of power factor.
- Advanced 8 bit microprocessor control circuit
- Reverse polarity protected by fuse
- **Ignition protection**
- Output short circuit protection
- Over power protection
- Switch mode technology
- Statue of charge indication by LED
- Compact size, light-weight

2-1. Battery Charging Curve

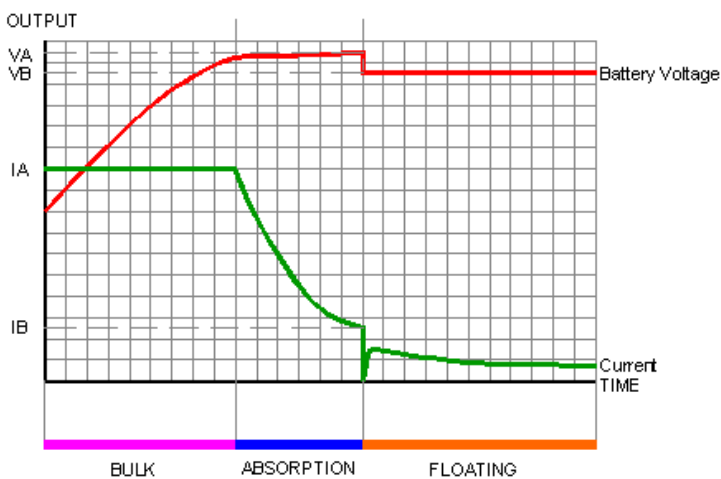

IuU Charging Characteristic

Model	12V / 5A	12V / 10A	24V / 5A	24V / 3A
VA	14.4V	14.4V	28.8V	28.8V
VB	13.6V	13.6V	27.2V	27.2V
IA	5A	10A	5A	2.5A
IB	0.75A	1.5A	0.75A	0.38A

2-2. Electrical Characteristic

Specification	Technical Data	
Model No	PC-0524	PC1012
Input Voltage	100-240VAC / 50~60Hz	
Input Current	0.95A Max.	1.9A Max.
Power Factor	PF: 0.98	
Output Voltage	14.4V DC	
Output Current	5A Max.	10A Max.
Output Power	75W Max.	150W Max.
Safety	CE , TUV	
EMC	FCC Class B; CISPR22:1997,Class B; ANSIC63.4-1992 EN55022:1998+A1:2000,Class B; EN55024:1998+A1:2001 EN61000-3-2:2000,Class A; EN61000-3-3:1995+A1:2001	
Dimensions	210 (L) x 85 (W) x 50 (H) mm / 8.26 (L) x 3.34 (W) x 1.96 (H) Inch	
Weight	1 kgs. / 2.2 Lbs.	

Specification	Technical Data	
Model No	PC-0324	PC-0524
Input Voltage	100-240VAC / 50~60Hz	
Input Current	0.95A Max.	1.9A Max.
Power Factor	PF: 0.98	
Output Voltage	28.8V DC	
Output Current	2.5A Max.	5A Max.
Output Power	75W Max.	150W Max.
Safety	CE , TUV	
EMC	FCC Class B; CISPR22:1997,Class B; ANSIC63.4-1992 EN55022:1998+A1:2000,Class B; EN55024:1998+A1:2001 EN61000-3-2:2000,Class A; EN61000-3-3:1995+A1:2001	
Dimensions	210 (L) x 85 (W) x 50 (H) mm / 8.26 (L) x 3.34 (W) x 1.96 (H) Inch	
Weight	1 kgs. / 2.2 Lbs.	

2-3. Mechanical Drawing

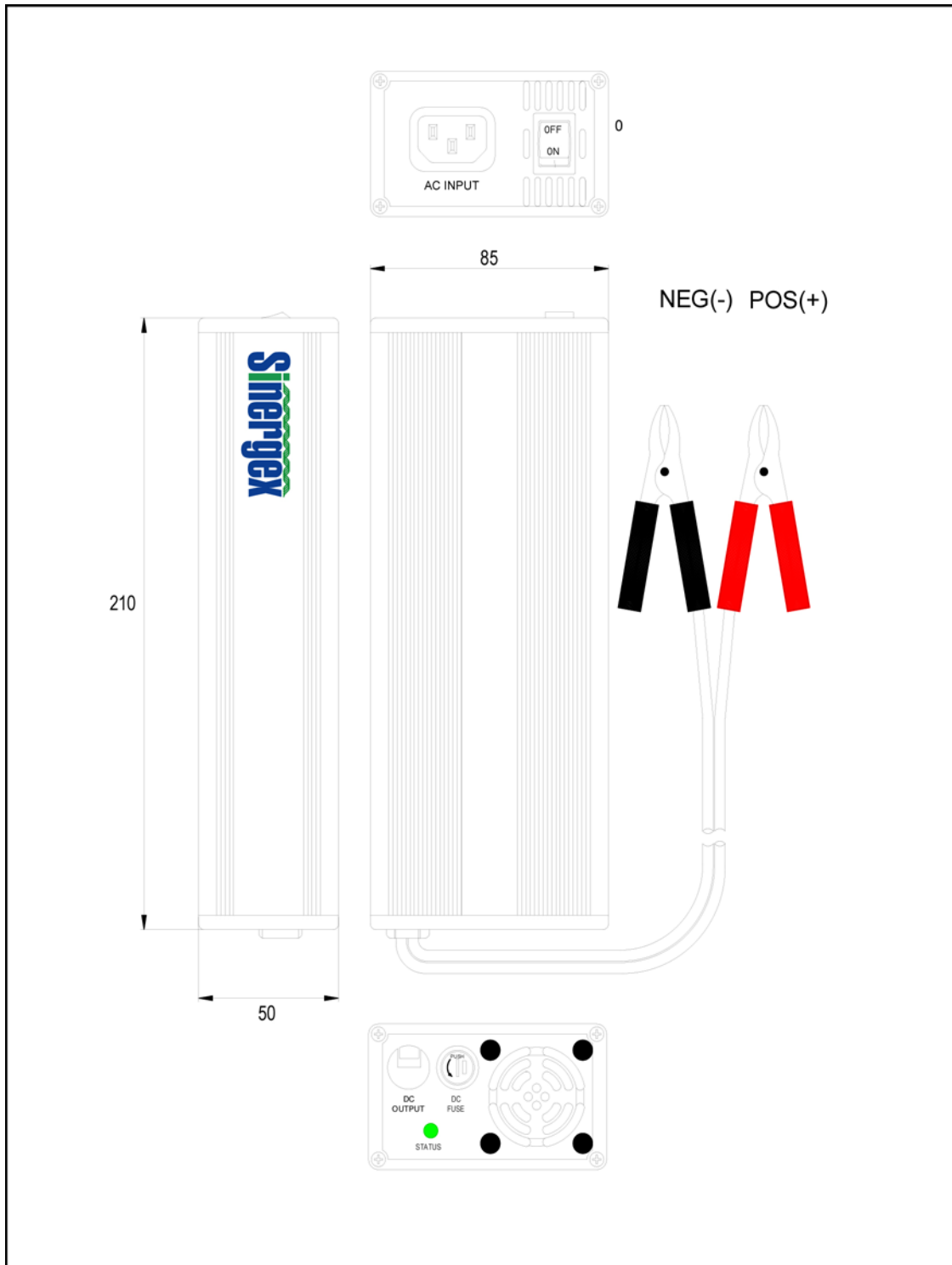

3. Introduction

This PureCharge series is a high frequency switch-mode 3-stage battery Charger, equipped with a micro-controller and PFC circuit to perform intelligent and automatic battery management and to provide reliable operation. Before using the PureCharge, **read all instructions and caution statements carefully** within this manual.

3-1. Front Panel Operations:

3-1-1. Front Panel:

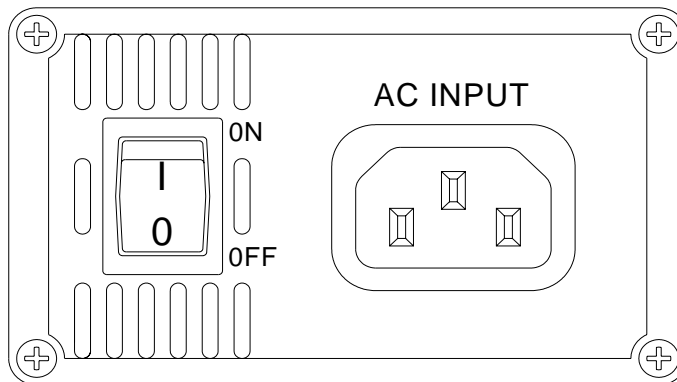

IEC RECEPTACLE TYPE

3-1-2. ON / OFF switch:

Switch the Power ON / OFF switch to the OFF position during installation.

3-1-3. LED Status

Charging Status	LED Indication
Fast Charge	Blinking Green Fast
Slow Charge	Blinking Green Slow
Floating Charge	Solid Green
Charging Fault	Blinking Red
Bad Battery or Wire Disconnection	Blinking Red

3-2. Rear Panel Operations:

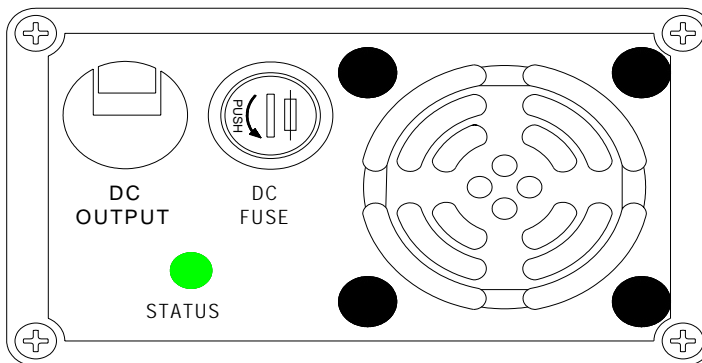

3-2-1. Air Vents:

Do not obstruct, allow at least 1 inch clearance for airflow.

3-2-2. DC Output terminals:

Connect to 12V / 24V batteries.

(+) is positive, (-) is negative. Reverse polarity connection will blow internal fuse and may damage the PureCharge permanently.

3-3. Troubleshooting:

Problems and Symptoms	Possible Cause	Solutions
Blinking "Red" LED	Battery is disconnected	Check the battery connection.
	Polarity reverse	Place proper polarity. Check DC fuse If broken, replace the same rating fuse.
	DC fuse broken	Check DC output fuse
LED light off	No AC power delivering	Check input power connection.
	Thermal shutdown	Make sure ventilation is not obstructed. Improve ventilation. Reduce ambient temperature.

3-4. Selection of battery types:

Sealed lead acid and open lead acid batteries selected for use.

Model No.	Battery Capacity (Min.)	Battery Capacity (Max.)
PC-0512	12V / 15Ah	12V / 50Ah
PC-1012	12V / 30Ah	12V / 100Ah
PC-0324	24V / 7.5Ah	24V / 25Ah
PC-0524	24V / 15Ah	24V / 50Ah



E-mail: office@sinergex.nl Website: www.sinergex.nl

2004.09